



April 30, 2026

Request For Proposals (RFP)

Date Posted: April 30, 2026

Date Due: May 15, 2026 by 5:00pm

Summary and Project Description:

The Centerville-Washington Park District (CWPD) is issuing a Request for Proposals for asphalt or concrete paving at Pleasant Hill Park. This project will cover the paving of an existing gravel path, please review the plans that are attached as Appendix A and provide a quote for the project.

Background and Need

The Centerville-Washington Park District (CWPD) strives to maintain multi use trails in the best way possible. This project will address an existing gravel path that has been in place for a number of years. Connections between neighborhoods and parks are an important piece in achieving access for residents. This project addresses that need and will be a benefit to the community.

Location and Project Details

The project location is Pleasant Hill Park located at 358 Zengel Drive Centerville, Ohio. Project details are listed in the attached plans as Appendix A.

Proposal Submittal

Proposals should include the following:

- Project estimate with a line-item cost breakdown
- Timeline for completion
- Warranty information
- Reference section
 - Description of previous experience with comparable projects
 - Key personnel who would be involved with this project, their previous project experience and qualifications. This information should include any sub-contractors

937.433.5155



www.cwpd.org



mail@cwpd.org



221 N. Main Street
Centerville, Ohio 45459





Evaluation

The following criteria will be used to evaluate proposals:

- a. Proposal suitability: proposal must include all requirements stated above and as detailed in the plans
- b. Experience and knowledge of similar projects and scope
- c. Ability to meet the established timeline and schedule
- d. Cost estimate based on the details and scope found in Appendix A

Centerville-Washington Park District Obligations and Rights:

Response to the RFP is entirely voluntary. This RFP does not and shall not commit the Centerville-Washington Park District or any of its agents to enter into any agreement, to pay any costs incurred in the preparation of any response to this RFP, or to procure or contract for any services or supplies.

The Centerville-Washington Park District reserves the right to accept or reject any or all responses to this RFP, to enter into contractual agreement with any individual or company submitting a response to the RFP, or to delay and/or cancel in part or in its entirety this RFP if it is in the best interest of the Centerville-Washington Park District, in its sole opinion, to do so.

Additional Information

Additional information about the Centerville-Washington Park District can be found on our website, www.cwpd.org. If you have any questions regarding this proposal, please contact me at tcarpenter@cwpd.org. Proposals may be submitted by email by the required deadline to tcarpenter@cwpd.org

Sincerely,

Tony Carpenter
Project & Planning Manager
221 N. Main St
Centerville, OH 45459

937.433.5155



www.cwpd.org



mail@cwpd.org



221 N. Main Street
Centerville, Ohio 45459



Appendix A

***See attached set of plans and Specifications**

937.433.5155



www.cwpd.org



mail@cwpd.org



221 N. Main Street
Centerville, Ohio 45459



Z:\project\Montgomery\Centerville\MOT-CEN-2603_PleasantHillParkPathwayPaving\MOTCEN2603_GN001.dwg, 22-Apr-26 2:03 PM

GENERAL NOTES AND DETAILS

ALL CONSTRUCTION METHODS, MATERIALS, AND SPECIFICATIONS SHALL COMPLY WITH THE CENTERVILLE WASHINGTON PARK DISTRICT CENTERVILLE WASHINGTON PARK DISTRICT ENGINEERING STANDARDS AND SPECIFICATIONS OR OHIO DEPARTMENT OF TRANSPORTATION CONSTRUCTION STANDARDS AND SPECIFICATIONS, WHICHEVER IS MORE RESTRICTIVE AS DETERMINED BY THE CENTERVILLE WASHINGTON PARK DISTRICT.

MODIFICATIONS

ANY MODIFICATIONS TO THE SPECIFICATIONS OR CHANGES TO THE WORK AS SHOWN ON THE DRAWINGS MUST HAVE PRIOR WRITTEN APPROVAL BY THE PARK DISTRICT.

FUNDING

DUE TO FUNDING, THE OWNER RESERVES THE RIGHT TO INCREASE, DECREASE, OR OMIT ANY ITEMS LISTED IN THE BID SCHEDULE.

NO FINAL UNIT PRICE ADJUSTMENTS PER ODOT 104.02 WILL BE MADE AT CONTRACT FINALIZATION.

CONTRACT WORK PERFORMED BY THE PARK DISTRICT

IF THE CONTRACTOR REFUSES OR FAILS TO PERFORM WORK OF ANY IMMEDIATE NATURE SUCH AS THE PLACEMENT OF BARRICADES, REPLACEMENT OF SIGNS, OR OTHER DEVICES, REQUIRED BY THIS CONTRACT IN A REASONABLE TIME, THE PARK DISTRICT WILL PERFORM THE NECESSARY WORK. THE CONTRACTOR SHALL REIMBURSE THE PARK DISTRICT AT THE RATE OF 2.5 TIMES THE ACTUAL COST OF LABOR, MATERIALS, AND EQUIPMENT NECESSARY TO PERFORM SUCH WORK. THE PARK DISTRICT SHALL NOTIFY OR ATTEMPT TO NOTIFY THE CONTRACTOR OF THE NECESSITY TO PERFORM SUCH WORK. THE PARK DISTRICT SHALL BE REIMBURSED BY A DEDUCTION FROM THE CONTRACTOR'S NEXT PAYMENT UNDER THE CONTRACT. REASONABLE TIME FOR ALL STREETS INVOLVED ON THIS CONTRACT IS 1 HOUR FROM THE TIME OF NOTIFICATION BY THE PARK DISTRICT.

MISCELLANEOUS

COMPENSATION FOR THE WORK AS SHOWN ON THE PLANS SHALL BE AT THE UNIT PRICES INCLUDED ON THE BID PROPOSAL. NO SEPARATE PAYMENT WILL BE MADE FOR TASKS (NOT ALL INCLUSIVE) INCLUDING ITEMS SUCH AS MOBILIZATION, RECORD DRAWINGS AND CONNECTIONS TO EXISTING FACILITIES.

UNDERGROUND UTILITIES

THE LOCATIONS OF THE UNDERGROUND UTILITIES SHOWN ON THE PLANS ARE AS OBTAINED FROM THE OWNERS OF THE UTILITY AS REQUIRED BY SECTION 153.64 ORC. EXISTING UTILITIES ARE SHOWN IN THEIR APPROXIMATE LOCATION ACCORDING TO THE BEST AVAILABLE DATA. THE CONTRACTOR WILL BE RESPONSIBLE FOR LOCATING THEM IN THE FIELD PRIOR TO CONSTRUCTION AND WILL BE RESPONSIBLE FOR ANY DAMAGE DONE TO THEM. CONTRACTOR TO CONTACT OHIO UTILITIES PROTECTION SERVICE (1-800-362-2764) 48 HOURS PRIOR TO CONSTRUCTION.

NON-MEMBERS MUST BE CALLED DIRECTLY.

SUBCONTRACTOR SUPERVISION

THE CONTRACTOR IS REQUIRED TO HAVE A PROJECT SUPERVISOR ON-SITE TO SUPERVISE THE SUBCONTRACTOR FOR QUALITY CONTROL PURPOSES AND TO PROVIDE ANY NECESSARY ASSISTANCE TO THE SUBCONTRACTOR TO ENSURE QUALITY WORK.

COST OF THIS ITEM SHALL BE INCLUDED IN THE COST OF RELATED PAY ITEMS OF THIS PROJECT.

SAFETY

THE CONTRACTOR SHALL BE SOLELY RESPONSIBLE FOR COMPLYING WITH ALL FEDERAL, STATE, AND LOCAL SAFETY REQUIREMENTS, TOGETHER WITH EXERCISING PRECAUTIONS AT ALL TIMES FOR THE PROTECTION OF PERSONS (INCLUDING EMPLOYEES) AND PROPERTY. IT IS ALSO THE SOLE RESPONSIBILITY OF THE CONTRACTOR TO INITIATE, MAINTAIN, AND SUPERVISE ALL SAFETY REQUIREMENTS, PRECAUTIONS, AND PROGRAMS IN CONNECTION WITH THE WORK.

STAGING AREAS

THE PARK DISTRICT WILL IDENTIFY A STAGING AREA IN THE PARK FOR THE CONTRACTOR TO STAGE MATERIAL AND EQUIPMENT.

MUD

THE TRACKING OR SPILLING OF MUD, DIRT, OR DEBRIS UPON CITY STREETS IS PROHIBITED, AND ANY SUCH OCCURRENCE SHALL BE CLEANED UP IMMEDIATELY BY THE CONTRACTOR.

NONRUBBER TIRE VEHICLES

NO NONRUBBER TIRE VEHICLES SHALL BE MOVED ON CITY STREETS. EXCEPTIONS MAY BE GRANTED BY THE CITY WHERE SHORT DISTANCES AND SPECIAL CIRCUMSTANCES ARE INVOLVED. GRANTING OF EXCEPTIONS MUST BE IN WRITING AND ANY RESULTING DAMAGE MUST BE REPAIRED TO THE SATISFACTION OF THE CITY. THE CONTRACTOR SHALL USE EXTREME CARE WHEN OPERATING NONRUBBER TIRE VEHICLES ON STREETS OR DRIVEWAYS TO AVOID MARKING OR DAMAGING THE PAVEMENT. PROTECTION OF THE PAVEMENT FROM DAMAGE RESULTING FROM THE TRACKS OF NONRUBBER TIRE VEHICLES UTILIZED IN TRENCH EXCAVATION SHALL BE REQUIRED. A WOOD PLANK SYSTEM, USED TIRES, RUBBER MATS, OR OTHER MEANS AS APPROVED BY THE CITY'S REPRESENTATIVE SHALL BE USED TO PROTECT THE PAVEMENT. THE COST OF THIS WORK SHALL BE INCLUDED IN THE UNIT PRICE BID FOR THE VARIOUS ITEMS OF THE CONTRACT.

CONSTRUCTION NOISE

IN ORDER TO MINIMIZE ANY ADVERSE CONSTRUCTION NOISE IMPACTS, ANY POWER-OPERATED CONSTRUCTION-TYPE DEVICES SHALL NOT BE OPERATED BETWEEN THE HOURS SPECIFIED IN THE PARK DISTRICT NOISE ORDINANCE. IF THERE IS NO NOISE ORDINANCE IN PLACE, POWER-OPERATED CONSTRUCTION-TYPE DEVICES SHALL NOT BE OPERATED BETWEEN THE HOURS OF 7:00 PM TO 7:00AM.

HAUL ROADS

WHEN PICKING A DUMP SITE, CONTRACTOR IS TO TAKE INTO CONSIDERATION THE HAUL ROAD ROUTE AND ANY NECESSARY ROADWAY REPAIR CAUSED BY HAULING TO THE DUMP SITE.

PRIOR TO HAULING EQUIPMENT OR MATERIALS, THE CONTRACTOR SHALL PROVIDE WRITTEN NOTIFICATION TO THE CITY OF THE SPECIFIC ROADS OR STREETS ON THE HAUL ROUTE. IF THE HAUL ROUTE INCLUDES ROADS AND STREETS THAT ARE NOT UNDER THE JURISDICTION AND CONTROL OF THE CITY OR OF THE STATE, THE CONTRACTOR MUST USE LOCAL ROADS AND STREETS THAT ARE NOT RESTRICTED BY LOCAL AUTHORITIES. IF IT IS DETERMINED BY THE CITY THAT THE HAUL ROADS USED TO HAUL EQUIPMENT AND MATERIALS TO THE DUMP SITE WERE DAMAGED FROM THIS OPERATION, THE CITY WILL ORDER THE CONTRACTOR TO PERFORM IMMEDIATE AND PRACTICAL REPAIRS TO ENSURE REASONABLY NORMAL TRAVELING CONDITIONS AND BRING PAVEMENT CONDITIONS BACK TO CONDITIONS EQUAL OR BETTER THAN PRE-OPERATION CONDITIONS AT THE CONTRACTOR'S EXPENSE. THE CONTRACTOR SHALL TAKE ALL THIS INTO CONSIDERATION WHEN PICKING A DUMP SITE.

THE CONTRACTOR SHALL NOT FILE A CLAIM FOR DELAYS OR OTHER IMPACTS TO THE WORK CAUSED BY DISPUTE WITH THE LOCAL AUTHORITIES REGARDING THE USE OF LOCAL ROADS OR STREETS AS HAUL ROADS. THE CONTRACTOR SHALL SAVE THE CITY AND THE STATE HARMLESS FOR ANY CLOSURES OR HAULING RESTRICTION OUTSIDE THE PROJECT LIMITS BEYOND THE CONTROL OF THE CITY OR ODOT.

GRAFFITI AND VANDALISM

THE CONTRACTOR SHALL BE RESPONSIBLE FOR REMOVAL AND REPLACEMENT OF ANY CONCRETE WORK OR OTHER PAY ITEM UNDER THIS CONTRACT WHICH IS DEEMED UNACCEPTABLE BY THE PARK DISTRICT DUE TO GRAFFITI OR VANDALISM DAMAGE.

CONTROL OF SPILLS

BEST CONSTRUCTION PRACTICES ARE TO BE IMPLEMENTED TO MINIMIZE WATER QUALITY IMPACTS. IDLE EQUIPMENT, PETROCHEMICALS, AND TOXIC/HAZARDOUS MATERIALS SHALL NOT BE STORED NEAR DRAINAGE WAYS, DITCHES, OR STREAMS. REFUELING SHALL NOT BE UNDERTAKEN NEAR DRAINAGE WAYS, DITCHES, OR STREAMS. A SPILL CONTAINMENT KIT IS TO BE MAINTAINED ONSITE THROUGHOUT CONSTRUCTION ACTIVITIES. SPILLS OF FUELS, OILS, CHEMICALS, OR OTHER MATERIALS WHICH COULD POSE A THREAT TO GROUNDWATER SHALL BE CLEANED UP IMMEDIATELY. IF THE SPILL IS A REPORTABLE AMOUNT, THE LOCAL FIRE DEPARTMENT IS TO BE CONTACTED.

ASPHALT

ALL ODOT CONSTRUCTION AND MATERIAL SPECIFICATIONS SHALL APPLY TO THIS PROJECT, EXCLUDING THE BINDER PRICE ADJUSTMENT PER ODOT 401.20. ALL ASPHALT DELIVERED SHALL BE ACCOMPANIED WITH A LOAD TICKET AS PER ITEM 401.21.

WORK LIMITS

ALL WORK SHALL BE WITHIN EXISTING OR PROPOSED RIGHT-OF-WAY AND/OR CONSTRUCTION LIMITS UNLESS OTHERWISE INSTRUCTED BY THE PARK DISTRICT. SEE PAGE 4 FOR DESCRIPTION ON WORK LIMITS.

THE WORK LIMITS SHOWN ON THESE PLANS ARE FOR PHYSICAL CONSTRUCTION ONLY. THE INSTALLATION AND OPERATION OF ALL TEMPORARY TRAFFIC CONTROL AND TEMPORARY TRAFFIC CONTROL DEVICES REQUIRED BY THESE PLANS SHALL BE PROVIDED BY THE CONTRACTOR WHETHER INSIDE OR OUTSIDE THESE WORK LIMITS.

TESTING AND CERTIFICATION

PROVIDE TESTING OF AND CERTIFICATION THAT MATERIAL SUPPLIED FOR THIS PROJECT MEETS THE PROJECT SPECIFICATIONS, IF REQUIRED.

POTENTIAL ITEMS FOR TESTING CONSIST OF TRENCH BACKFILL, EMBANKMENT, AND CONCRETE, WHICH MAY BE PERFORMED BY THE PARK DISTRICT IF THEY SUSPECT DEFECTIVE WORK OR MATERIALS.

PAYMENT FOR CERTIFICATION OF WORK SHALL BE INCIDENTAL TO THE VARIOUS ITEMS IT IS RELATED TO AND SHALL INCLUDE ALL COST RELATED TO PROVIDING THE CERTIFICATION. COST OF ANY TESTING BY A TESTING LAB CONTRACTED BY THE PARK DISTRICT SHALL BE BORNE BY THE PARK DISTRICT, UNLESS THE TEST DOES NOT MEET PROJECT SPECIFICATIONS OR WORK IS FOUND TO BE DEFECTIVE, AT WHICH POINT, THE CONTRACTOR SHALL PAY THE EXPENSES FOR TESTING.

ESTIMATED AND CONTINGENT QUANTITIES

THESE PLANS INCLUDE ESTIMATED AND CONTINGENCY QUANTITIES THAT MAY OR MAY NOT BE USED. ANY UNUSED MATERIAL PURCHASED BY THE CONTRACTOR WILL NOT BE PURCHASED OR REIMBURSED BY THE PARK DISTRICT. THE PARK DISTRICT WILL NOT APPROVE ANY WORK DELAYS BECAUSE OF THE LACK OF MATERIALS AT THE SITE. ANY RESTOCKING FEES THAT MAY BE CHARGED WILL ALSO BE THE RESPONSIBILITY OF THE CONTRACTOR.

SEALING COMPOUND

ALL EXPOSED CONCRETE SHALL HAVE A CURING AND SEALING COMPOUND APPLIED. THE CURING AND SEALING COMPOUND SHALL BE APPLIED IN 2 COATS. CURING AND SEALING COMPOUND COLOR TO BE APPROVED BY PARK DISTRICT.

SPECIAL CONCRETE CONDITIONS

ALL CONCRETE WORK MUST BE FINISHED TO THE SATISFACTION OF THE PARK DISTRICT.

REVIEW OF DRAINAGE FACILITIES

BEFORE ANY WORK IS STARTED ON THE PROJECT AND BEFORE FINAL ACCEPTANCE BY THE PARK DISTRICT, REPRESENTATIVES OF THE PARK DISTRICT AND THE CONTRACTOR SHALL MAKE AN INSPECTION OF ALL EXISTING SEWER THAT MAY BE AFFECTED BY THE WORK AND ARE TO REMAIN IN SERVICE. THE CONDITION OF THE EXISTING CONDUITS AND THEIR APPURTENANCES SHALL BE DETERMINED FROM FIELD OBSERVATIONS. RECORDS OF THE INSPECTION SHALL BE KEPT IN WRITING BY THE PARK DISTRICT.

ALL NEW CONDUITS, INLETS, CATCH BASINS, AND MANHOLES CONSTRUCTED AS A PART OF THE PROJECT SHALL BE FREE OF ALL FOREIGN MATTER AND IN A CLEAN CONDITION BEFORE THE PROJECT WILL BE ACCEPTED BY THE PARK DISTRICT.

ALL EXISTING SEWERS INSPECTED INITIALLY BY THE ABOVE-MENTIONED PARTIES SHALL BE MAINTAINED AND LEFT IN A CONDITION REASONABLY COMPARABLE TO THAT DETERMINED BY THE ORIGINAL INSPECTION. ANY CHANGE IN THE CONDITION RESULTING FROM THE CONTRACTOR'S OPERATIONS SHALL BE CORRECTED BY THE CONTRACTOR TO THE SATISFACTION OF THE PARK DISTRICT.

PAYMENT FOR ALL OPERATIONS DESCRIBED ABOVE SHALL BE INCLUDED IN THE CONTRACT PRICE FOR THE PERTINENT 611 CONDUIT ITEMS.

ITEM 304 AGGREGATE BASE, LIMESTONE, AS PER PLAN

THIS ITEM OF WORK SHALL CONSIST OF THE WORK AS DESCRIBED IN OHIO DEPARTMENT OF TRANSPORTATION ITEM 304, AGGREGATE BASE, EXCEPT AS HEREIN MODIFIED.

THIS ITEM SHALL ALSO INCLUDE SATURATING THE AGGREGATE BASE WITH WATER DURING PLACEMENT OF EACH LIFT PRIOR TO COMPACTING (IF APPLICABLE).

THIS WORK SHALL INCLUDE "PROOF ROLLING" WITH LOADED TANDEM DUMP TRUCK AS DIRECTED BY THE PARK DISTRICT UNTIL NO DEFLECTION OR TIRE INDENTATION IN THE AGGREGATE BASE IS PRESENT.

PAYMENT FOR ITEM 304, AGGREGATE BASE LIMESTONE, AS PER PLAN, FOR ALL OPERATIONS DESCRIBED ABOVE SHALL BE AT THE CONTRACT CUBIC YARD BID PRICE AND SHALL INCLUDE ALL LABOR, MATERIAL, AND EQUIPMENT REQUIRED TO COMPLETE THIS ITEM OF WORK.

ITEM 659 SEEDING AND MULCHING, AS PER PLAN

THIS ITEM OF WORK SHALL CONSIST OF THE WORK AS DESCRIBED IN OHIO DEPARTMENT OF TRANSPORTATION ITEM 659 SEEDING AND MULCHING EXCEPT AS HEREIN MODIFIED.

ALL AREAS DESIGNATED FOR SEEDING SHALL HAVE A MINIMUM OF 6 INCHES OF TOPSOIL OVER THE ENTIRE AREA. ALL SEEDING SHALL BE DONE BY HYDRO SEEDING. THE AREA SHALL BE RAKED, ROLLED AND DRESSED READY FOR SEEDING. NO STONE OVER 1/2" IN SIZE PERMITTED AND NO EXCESS GRAVEL ALLOWED IN SEED BED. ALL AREAS SHALL BE ROCK-HOUNDED BEFORE SEEDING, EQUIPMENT, MATERIAL, AND LABOR INCIDENTAL TO THIS ITEM.

STRAW BLANKETS WILL NOT BE ALLOWED FOR SEEDING AND MULCHING.

COMMERCIAL FERTILIZER 12-12-12 SHALL BE INCLUDED IN ITEM 659 SEEDING AND MULCHING, AS PER PLAN AND SHALL BE APPLIED AT THE RATE OF 20 POUNDS PER 1000 SQUARE FEET.

SEEDING APPLICATION SHALL BE AT THE RATE OF 8 POUNDS PER 1000 SQUARE FEET. THE FOLLOWING "GREEN VELVET SPORTS MIX" SEED MIXTURE OR APPROVED EQUIVALENT SHALL BE USED THROUGHOUT THE LIMITS OF THIS PROJECT IN LIEU OF THE MIXTURES LISTED IN 659.09:
80% ELITE TURF TYPE TALL FESCUE
10% ELITE KENTUCKY BLUEGRASS
10% ELITE PERENNIAL RYEGRASS

SEEDING AND MULCHING SHALL BE APPLIED TO ALL AREAS OF EXPOSED SOIL WITHIN THE WORK LIMITS. QUANTITY CALCULATIONS FOR ITEM 659 SEEDING AND MULCHING, AS PER PLAN ARE BASED ON THESE LIMITS.

IT IS THE CONTRACTOR'S SOLE RESPONSIBILITY TO ENSURE THE GRASS IS ESTABLISHED TO THE SATISFACTION OF THE PARK DISTRICT, WHICH MAY REQUIRE WATERING AND RESEEDING THROUGHOUT THE LENGTH OF THIS CONSTRUCTION CONTRACT. THE CONTRACTOR SHALL ALSO BE RESPONSIBLE FOR THE FINAL SITE CLEANUP, GENERAL CARE AND REMOVAL OF ANY DEBRIS LOCATED IN THE PROJECT AREA TO THE PARK DISTRICT'S SATISFACTION. PAYMENT SHALL BE INCIDENTAL TO THIS ITEM.

PAYMENT FOR ITEM 659 SEEDING AND MULCHING, AS PER PLAN, FOR ALL OPERATIONS DESCRIBED ABOVE SHALL BE AT THE CONTRACT SQUARE YARD BID PRICE AND SHALL INCLUDE ALL LABOR, MATERIAL, AND EQUIPMENT REQUIRED TO COMPLETE THIS ITEM OF WORK.



SIDNEY, OHIO 937-497-0200
LOVELAND, OHIO 513-239-8554
WWW.CHOICEONEENGINEERING.COM

PLEASANT HILL PATHWAY PAVING
CENTERVILLE WASHINGTON PARK DISTRICT
GENERAL NOTES

REVISIONS:

FILE NAME
GN001

DRAWN BY
GAM

CHECKED BY
RRB

PROJECT No.
MOT-CEN-2603

DATE
04-22-2026

SHEET NUMBER

Z:\project\Montgomery\Centerville\MOT-CEN-2603_PleasantHillParkPathwayPaving\MOTCEN2603_GN001.dwg 22-Apr-26 2:03 PM

SIDEWALK AND CURB JOINTS

1. GENERAL: CONSTRUCT ISOLATION, CONSTRUCTION, AND CONTRACTION JOINTS, AND TOOL EDGINGS TRUE TO LINE WITH FACES PERPENDICULAR TO SURFACE PLANE OF CONCRETE. CONSTRUCT TRANSVERSE JOINTS AT RIGHT ANGLES TO CENTERLINE, UNLESS OTHERWISE INDICATED.
 - a. WHEN JOINING EXISTING SIDEWALK OR CURB, PLACE TRANSVERSE JOINTS TO ALIGN WITH PREVIOUSLY-PLACED JOINTS, UNLESS OTHERWISE INDICATED.
2. CONSTRUCTION JOINTS: SET CONSTRUCTION JOINTS AT SIDE AND END TERMINATION OF SIDEWALK OR CURB AND AT LOCATIONS WHERE SIDEWALK OR CURB OPERATIONS ARE STOPPED FOR MORE THAN ONE-HALF HOUR, UNLESS SIDEWALK OR CURB TERMINATES AT ISOLATION JOINTS.
3. ISOLATION JOINTS: FORM ISOLATION JOINTS OF PREFORMED JOINT-FILLER STRIPS ABUTTING MANHOLES, STRUCTURES, WALKS, OTHER FIXED OBJECTS, AND WHERE INDICATED.
 - a. LOCATE EXPANSION JOINTS AT INTERVALS OF 60' IN SIDEWALK AND 200' IN CURB, UNLESS OTHERWISE INDICATED.
 - b. THE EXPANSION JOINT MATERIAL SHALL BE FOAM TECH BY NMW, INC. OR EQUIVALENT. THE EXPANSION JOINT MATERIAL SHALL HAVE A "PEEL-OFF" TOP FOR CAULKING PURPOSES.
 - c. REMOVE "PEEL-OFF" TOP AFTER CONCRETE IS SET AND MAKE SURE THE EXPANSION JOINT MATERIAL IS 1/2" - 3/4" BELOW THE FINISHED CONCRETE SURFACE.

- d. PLACE JOINT FILLER (SONOLASTIC ULTRA, EUCOLASTIC 1, OR EQUIVALENT) IN LIME STONE COLOR IN THE TOP 1/2" - 3/4" OF JOINT FOLLOWING MANUFACTURER INSTALLATION RECOMMENDATION. CONTRACTOR TO PLACE WHITE SILICA SAND ON TOP OF JOINT FILLER AFTER INITIAL SET.
4. CONTRACTION JOINTS: FORM WEAKENED-PLANE CONTRACTION JOINTS, SECTIONING CONCRETE INTO AREAS AS INDICATED IN THE PLANS. CONSTRUCT CONTRACTION JOINTS FOR A DEPTH EQUAL TO AT LEAST ONE-FOURTH OF THE CONCRETE THICKNESS, WHERE INDICATED, AS FOLLOWS:
 - a. GROOVED JOINTS: FORM CONTRACTION JOINTS AFTER INITIAL FLOATING BY GROOVING AND FINISHING EACH EDGE OF JOINT WITH GROOVER TOOL TO THE FOLLOWING RADIUS. ELIMINATE GROOVER OVERFLOW SLURRY MARKS ON CONCRETE SURFACES PRIOR TO FINAL BROOMING. RADIUS TO BE 1/4" (6 MM).
 - b. SAWED JOINTS WILL NOT BE PERMITTED.
 - c. QUALITY WORK, AS DETERMINED BY THE PARK DISTRICT, SHALL BE PERFORMED OR THE NEW SIDEWALK OR CURB WILL BE REMOVED AND REDONE AT THE CONTRACTOR'S EXPENSE.
5. CURING COMPOUND: APPLY 2 COATS OF SUPER DIAMOND CLEAR CURING AND SEALING COMPOUND, WR MEADOWS, INC. CS-309-25, OR APPROVED EQUIVALENT PER MANUFACTURER'S RECOMMENDATIONS, ON ALL SURFACES, INCLUDING BACK, IMMEDIATELY AFTER FINISHING SURFACES.

TYPICAL SECTION

- ① ITEM 404 LVT - 3" ASPHALT SURFACE COURSE, PG 58-28 (1 LIFT)
- ② ITEM 304, 4" AGGREGATE BASE, LIMESTONE, AS PER PLAN
- ③ ITEM 204, SUBGRADE COMPACTION (IF APPLICABLE)
- ④ ITEM 659, SEEDING AND MULCHING, AS PER PLAN
- ⑤ ITEM 452 4" NON-REINFORCED CONC. PVMT.
- ⑥ EXISTING AGGREGATE BASE, TO BE CONFIRMED BY CONTRACTOR (SEE NOTE B & C BELOW)

NOTE:
 A) THE PARK DISTRICT WILL BE DECIDING UPON FINAL PAVEMENT COMPOSITION BASED ON THE BIDS RECEIVED.
 B) CONTRACTOR IS TO FIELD VERIFY DEPTH OF EXISTING AGGREGATE BASE EVERY 50' ALONG THE PATH. CONTRACTOR SHALL ADD GRAVEL AS REQUIRED TO ACHIEVE A MIN. DEPTH OF 4" FOR THE AGGREGATE BASE.
 C) IF NEEDED, CONTRACTOR SHALL ADD A 6" GRAVEL SHOULDER BASE OUTSIDE THE EDGE OF THE CONCRETE/ASPHALT PATH ON EACH SIDE.
 D) ITEM #2 IN THE TYPICAL SECTION ABOVE IS A CONTINGENT QUANTITY. USE OF THIS ITEM WILL BE DETERMINED BASED ON THE FINDINGS OF EXISTING AGGREGATE ON THE TRAIL (NOTE B ABOVE).
 E) FINAL PATH GRADE TO BE SET APPROXIMATELY 2" BELOW EXISTING GRADE OF GRAVEL. CONTRACTOR TO COORDINATE WITH THE PARK DISTRICT.
 * WHEREVER EXISTING GRADE IS < 2%, A MORE GRADUAL CROSS SLOPE MAY BE USED. MINIMUM CROSS SLOPE SHALL BE 1/8"/1'.

ESTIMATED QUANTITIES

ASPHALT

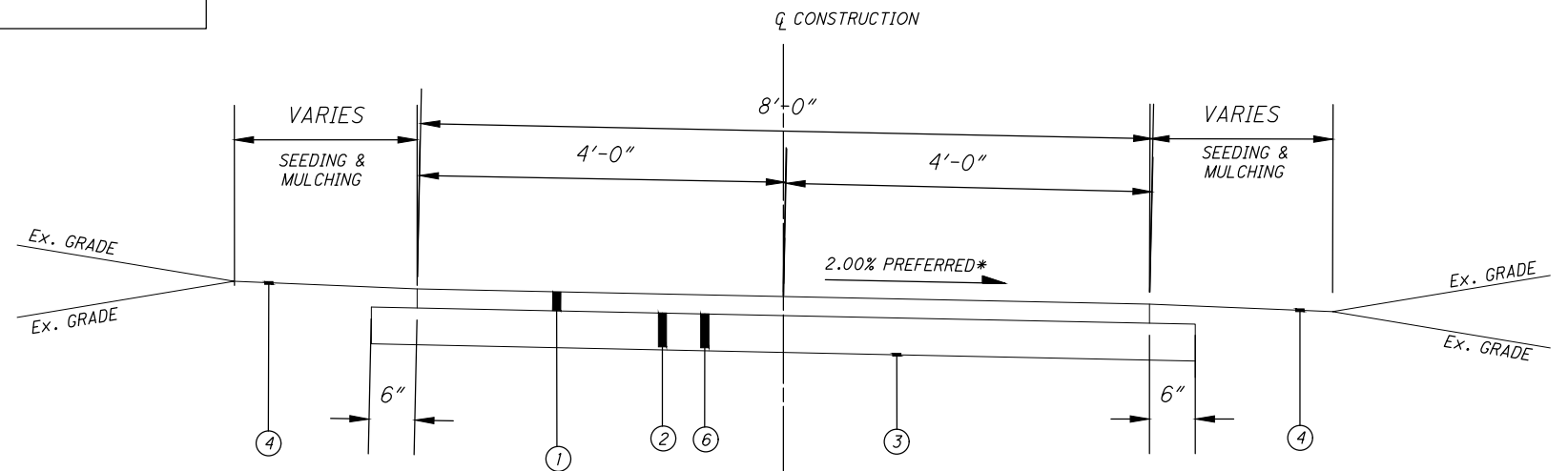

ALTERNATE #1: CONCRETE PATH

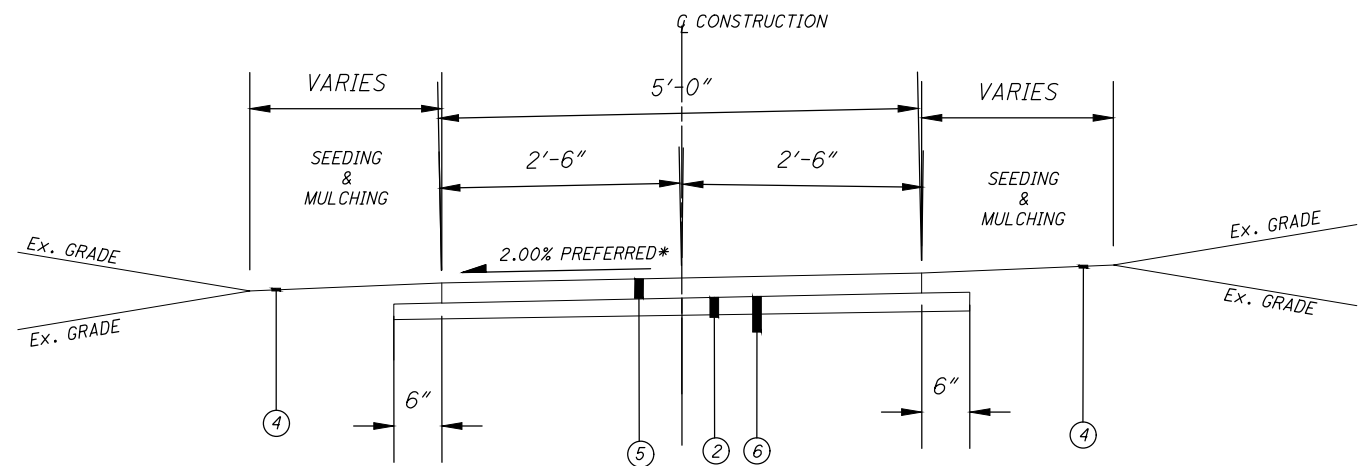

REVISIONS:

FILE NAME
GN001

DRAWN BY
GAM

CHECKED BY
RRB

PROJECT No.
MOT-CEN-2603

DATE
04-22-2026

SHEET NUMBER

Z:\project\Montgomery\Centerville\MOT-CEN-2603_PleasantHillParkPathwayPaving\Schematic_Plan.dwg 22-Apr-26 2:03 PM



**PLEASANT HILL PATHWAY PAVING
CENTERVILLE WASHINGTON PARK DISTRICT
SCHEMATIC PLAN**

REVISIONS:

FILE NAME	GB001
DRAWN BY	GAM
CHECKED BY	RRB
PROJECT No.	MOT-CEN-2603
DATE	04-22-2026
SHEET NUMBER	